

FASTENERS FOR HAND-HELD DEVICES

BULTEN IS RENOWNED FOR MANUFACTURING AND SUPPLYING HIGH PRECISION AND QUALITY FASTENERS TO VARIOUS INDUSTRIES AROUND THE GLOBE.



FASTENERS FOR HAND-HELD DEVICES

Bulten is renowned for manufacturing and supplying high precision and quality fasteners to various industries around the globe. With its latest technologies and manufacturing capabilities, Bulten is able to provide a total fastening solution for the mobile handsets industry. Bulten's miniature brass inserts and miniature sheet metal fasteners are specially designed for mobile handset applications.

A wide range of types and designs are available to suit a variety of host materials and insertion methods. Each part is engineered to meet critical performance requirements and to optimize production efficiency and output.

SONIC-LOK®

SONIC-LOK®, is designed for rapid installation into thermoplastics using heat or ultrasonics. It features opposed helical knurl bands to provide a combination of high torque and pull out resistance. Headed versions are also available.

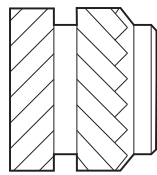

MINI-SMF

MINI-SMF is range of miniature threaded fasteners developed specifically for use in thin sheet Mobile Phone applications. The various types, Laser Weld, Riveting and Self- Clinch, allow designers to select a part to exactly suit their application and assembly requirements.



MINI-TECH®

MINI-TECH® is a miniature symmetrical insert with the design features and characteristics of the larger Tech-Sonic® range. It is ideal for today's very small plastic products, such as mobile phones. It allows the use of very small screws and provides complete re-usability, with no risk of thread stripping. Headed versions are also available.

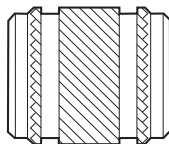

TMP SCREW

The TMP Screw is a range of direct screw fasteners for use in thermoplastics. The key design aspects include a profiled thread root to assist plastic flow, a 30° flank angle to reduce boss bursting forces and an 8° pitch angle which combine to give low installation torques with high stripping torques. For those applications not requiring the high levels of thread re-use and high clamping torque, (properties associated with threaded inserts) TMP screws offer an economical solution to plastics assembly and has distinct advantages over other direct screw fixings.

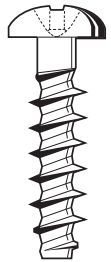

NYLON PATCH PROCESSING

Bulten can offer a wide range of thread locking and sealing solutions, eliminating the need for secondary locking devices. Nylon Patch when applied, is permanently fused onto the thread of the screw or threaded component. The patch increases the prevailing torque and provides excellent vibration resistance, allowing the screw to be locked in any position when assembled.



FASTENERS FOR HAND-HELD DEVICES

We develop Miniature fasteners for Smartphones,
Watches GPS devices, Tablets, Notebooks,
Cameras and Gaming Accessories.



MINIATURE SONIC-LOK[®] INSERTS

SONIC-LOK[®], is designed for rapid installation into thermoplastics using heat or ultrasonics. Moulding-in is also an option. It features opposed helical knurl bands to provide a combination of high torque and pull out resistance. Headed versions are also available.

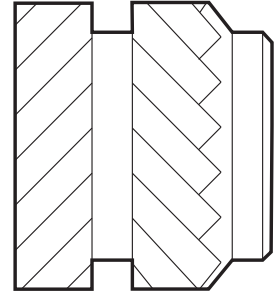

ADVANTAGES

- Permits thin boss walls allowing compact boss designs
- Provides high torque and pull out resistance
- Rapid installation using heat or ultrasonics
- Self aligning – assists installation
- A range of standard lengths available

DESIGN GUIDE

HOLE PREPARATION

Moulded holes are recommended. The taper on the moulded hole should be 1° inclusive and the diameter recommended should apply at the point reached by the bottom of the insert. The top of hole should not be chamfered or counterbored. Hole diameter tolerance -0.00 +0.05mm.

BOSS WALL THICKNESS

Where thinner boss walls are required these can often be accommodated, but consultation with your local Bulten Technology Centre or Sales Office and pre-production testing is strongly advised.

INSTALLATION

The insert may be installed using either a pre-heating method or using heat generated by ultrasonic vibrations. Where pre-heating is used care must be

exercised to ensure that the insert softens but does not melt the plastic. This will avoid any tendency to generate plastic flash around the top of the insert or boss damage. Ultrasonic installation is best carried out using low amplitude vibrations and with the minimum power consistent with satisfactory softening of the plastic material. In either case excessive pressure should be avoided, since this may result in the insert being forced into the hole without allowing the plastic to soften and flow around the insert profile.

PERFORMANCE DATA

Performance figures which are typical values based on application testing, please refer to FMP-04-1.

MINIATURE SONIC-LOK® INSERTS

PRODUCT RANGE

MINIATURE SONIC-LOK® can be supplied with and without a head to suit application requirements. The range includes thread sizes M1.2, M1.4, & M1.6 in a variety of lengths and diameters. See the product range table below. If a part does not suit your application, contact Bulten with your exact requirements.

TECHNICAL DATA

INSERTS

STANDARD MATERIAL - BRASS - Code (B)

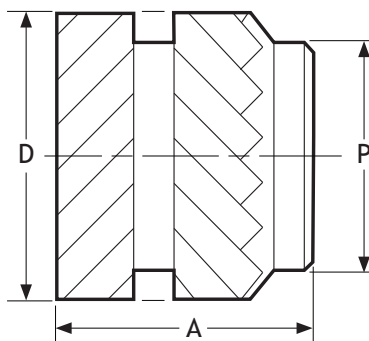

HEADED INSERTS

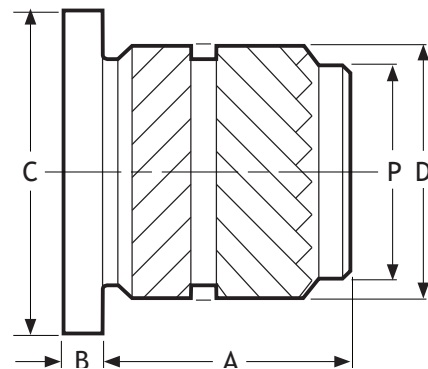

GENERAL DIMENSIONS - INSERTS

Product Code	Thread Size	Standard Lengths A	Knurl Diameter D	Knurl Diameter Code **	Spigot Diameter P	Hole Size -0.00 +0.05	Min Boss Wall Thickness
SL	M1.2	1.8, 2.0, 2.2	2.10		1.75	1.80	0.70
SL	M1.4	1.8, 2.0, 2.2, 2.5, 2.7, 3.0	2.30		1.90	1.95	0.70
SL	M1.6	2.0, 2.2, 2.35, 2.5, 2.7, 3.0	2.50		2.10	2.15	0.80
SL	M1.4	1.8, 2.0, 2.2, 2.5	2.10	OD2.1	1.75	1.80	0.70
SL	M1.4	1.8, 2.0, 2.2, 2.5, 2.7, 3.0	2.50	OD2.5	2.10	2.15	0.80
SL	M1.6	2.0, 2.2, 2.5, 2.65, 3.0	2.35	OD2.35	1.95	2.00	0.75

NOTE: Product Codes in bold are Bulten standard parts.

GENERAL DIMENSIONS - HEADED INSERTS

Product Code	Thread Size	Lengths A	Head Thickness B	Head Diameter C	Knurl Diameter D	Spigot Diameter P	Hole Size -0.00 +0.05	Min Boss Wall Thickness
SHK	M1.4	2.1, 2.35, 2.55, 2.85	0.35	2.80	2.30	1.90	1.95	0.70
SHK	M1.6	2.1, 2.35, 2.55, 2.85, 3.05, 3.35	0.35	3.00	2.50	2.10	2.15	0.80

HOW TO SPECIFY

INSERTS

Product Code	SL-B-M1.4-2.0
Material	SL- B -M1.4-2.0
Thread Size	SL-B- M1.4 -2.0
Length	SL-B-M1.4- 2.0
Knurl Diameter Code**	SL-B-M1.4-2.0- OD2.1

HEADED INSERTS

Product Code	SHK-B-M1.4-2.55
Material	SHK- B -M1.4-2.55
Thread Size	SHK-B- M1.4 -2.55
Length	SHK-B-M1.4- 2.55

** Specify for non standard diameters only.

MINI-TECH® INSERTS

MINI-TECH® is a miniature symmetrical insert with the design features and characteristics of the larger Tech-Sonic® range. It is ideal for today's very small plastic products, such as mobile phones. It allows the use of very small screws and provides complete re-usability, with no risk of thread stripping. Headed versions are also available.

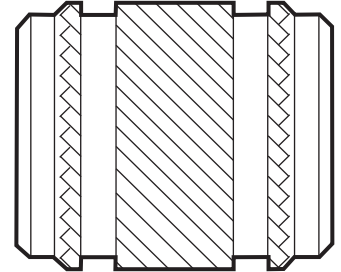

ADVANTAGES

- Symmetrical, does not require orientation
- Miniature product size
- Permits thin boss walls allowing compact boss designs
- Provides high torque and pull out resistance
- Rapid installation using heat
- Self aligning - assists installation
- A range of standard lengths available

DESIGN GUIDE

HOLE PREPARATION

Moulded holes are recommended. The taper on the moulded hole should be 0.5° inclusive and the diameter recommended should apply at the point reached by the bottom of the insert. The top of hole should not be chamfered or counterbored. Hole diameter tolerance -0.00 +0.05mm.

BOSS WALL THICKNESS

It may be possible to accommodate thinner boss walls to suit specific application requirements, however, consultation with your local Bulten Technology Centre or Sales Office and pre-production testing is strongly advised.

INSTALLATION

The insert has been designed to be installed using a pre-heating process. It is important that the insert softens but does not melt the plastic. This will avoid any tendency to generate plastic flash around the top of the insert or boss damage and ensure optimum performance.

Excessive pressure should be avoided, since this may result in the insert being forced into the hole without allowing the plastic to soften and flow around the insert profile.

PERFORMANCE DATA

Performance figures which are typical values based on application testing, please refer to FMP-04-1.

MINI-TECH® INSERTS

PRODUCT RANGE

MINI-TECH® can be supplied with and without a head to suit application requirements. The range includes thread sizes M1.2, M1.4, & M1.6 in a variety of lengths and diameters. See the product range table below. If a part does not suit your application, contact Bulten with your exact requirements.

TECHNICAL DATA

INSERTS

STANDARD MATERIAL - BRASS - Code (B)

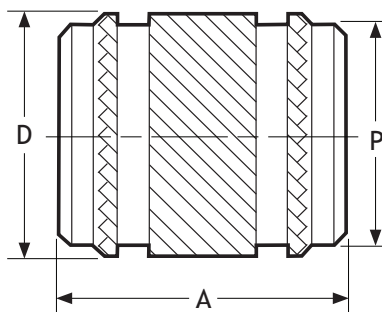

HEADED INSERTS

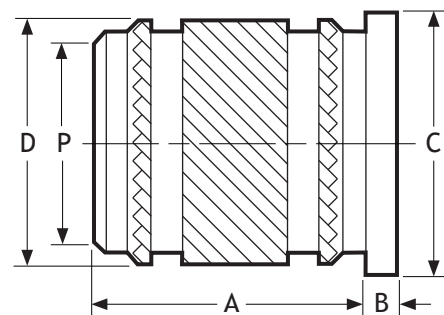

GENERAL DIMENSIONS - INSERTS

Product Code	Thread Size	Standard Lengths A	Knurl Diameter D	Knurl Diameter Code **	Spigot Diameter P	Hole Size -0.00 +0.05	Min Boss Wall Thickness
MTEC	M1.2	1.8, 2.0, 2.2, 2.5	2.10		1.75	1.80	0.70
MTEC	M1.4	1.5, 1.8, 2.0, 2.2, 2.5	2.20		1.85	1.90	0.70
MTEC	M1.6	2.0, 2.2, 2.5, 2.7, 3.0	2.50		2.10	2.15	0.80
MTEC	M1.4	1.8, 2.0, 2.2, 2.5	2.05	OD2.05	1.75	1.80	0.70
MTEC	M1.4	1.8, 2.0, 2.2, 2.5, 2.7, 3.0	2.50	OD2.5	2.10	2.15	0.80

NOTE: Product Codes in bold are Bulten standard parts.

GENERAL DIMENSIONS - HEADED INSERTS

Product Code	Thread Size	Lengths A	Head Thickness B	Head Diameter C	Knurl Diameter D	Spigot Diameter P	Hole Size -0.00 +0.05	Min Boss Wall Thickness
HMTEC	M1.4	2.1, 2.35, 2.50, 2.80	0.35	2.80	2.30	1.85	1.95	0.70
HMTEC	M1.6	2.1, 2.30, 2.50, 2.80, 3.00, 3.30	0.4	3.00	2.50	2.10	2.15	0.80

HOW TO SPECIFY

INSERTS

Product Code	MTEC-B-M1.4-2.0
Material	MTEC-B-M1.4-2.0
Thread Size	MTEC-B- M1.4 -2.0
Length	MTEC-B-M1.4- 2.0
Knurl Diameter Code**	MTEC-B-M1.4-2.0- OD2.05

HEADED INSERTS

Product Code	HMTEC-B-M1.6-2.50
Material	HMTEC-B-M1.6-2.50
Thread Size	HMTEC-B- M1.6 -2.50
Length	HMTEC-B-M1.6- 2.50

** Specify for non standard diameters only.

INSERTS FOR PLASTICS

INSTALLATION DEMONSTRATION

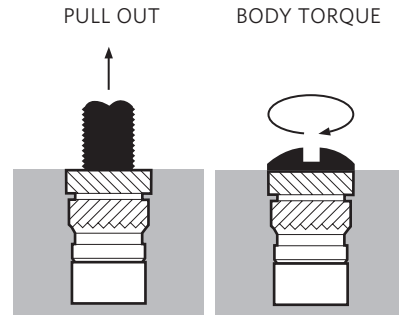
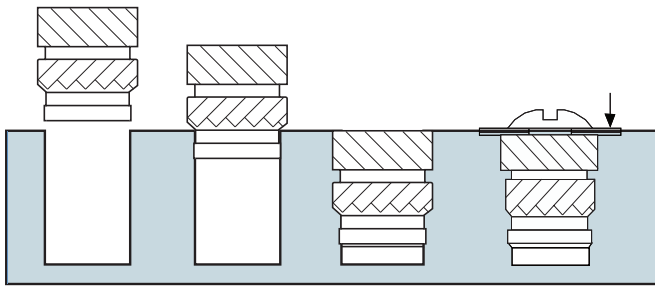

Please Note: The top of hole should not be chamfered or counterbored.

Product Code	PC/ABS		PC		PC GF15%	
	Pull Out (N)	Body Torque (Ncm)	Pull Out (N)	Body Torque (Ncm)	Pull Out (N)	Body Torque (Ncm)
SL-B-M1.2-2.0	110	16	130	18	140	20
SL-B-M1.4-2.0	140	19	165	23	180	25
SL-B-M1.4-2.5	180	23	210	27	230	30
SL-B-M1.4-3.0	215	28	250	33	270	36
SL-B-M1.6-2.0	160	23	190	28	210	31
SL-B-M1.6-2.5	215	28	255	34	280	37
SL-B-M1.6-3.0	250	33	300	39	330	42

Product Code	PC/ABS		PC		PC GF15%	
	Pull Out (N)	Body Torque (Ncm)	Pull Out (N)	Body Torque (Ncm)	Pull Out (N)	Body Torque (Ncm)
MTEC-B-M1.2-2.0	120	15	145	17	155	19
MTEC-B-M1.2-2.5	160	19	185	23	205	25
MTEC-B-M1.4-2.0	155	17	180	21	200	23
MTEC-B-M1.4-2.5	200	21	230	24	255	26
MTEC-B-M1.6-2.0	175	20	210	25	230	27
MTEC-B-M1.6-2.5	235	25	280	30	310	32
MTEC-B-M1.6-3.0	270	30	330	35	360	37

Performance figures shown above are typical values based on application testing. Contact Bulten when an insert has to meet a specific minimum performance requirement.

MINI-TECH® SPECIAL VARIANTS

PRODUCT RANGE

The standard MINI-TECH® range features a 45° helical knurl and a free fit location spigot. A number of special variants have been made to suit either application requirements or customer defined knurled profiles.

TAPER-LOK

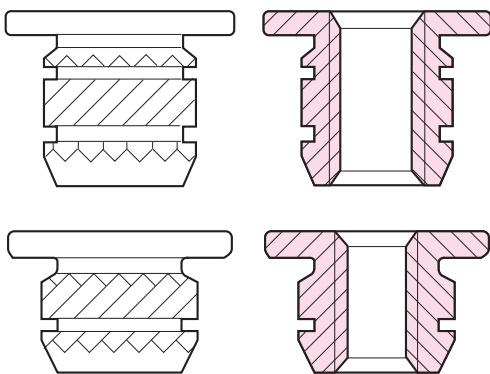

KNURL PROFILES

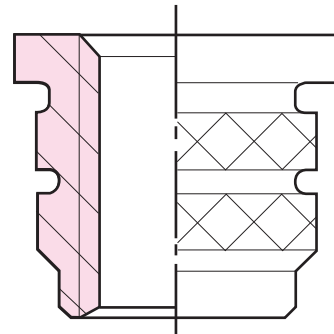

For some applications where the installation process requires the moulding to be moved after the inserts have been located into their receiving holes, but prior to installation.

A free fit location spigot may not provide adequate engagement to prevent the inserts from being dislodged. Taper-Lok was developed to eliminate this problem, a locking taper at the front of the insert securely holds the insert in place, when a light downward pressure is applied to the insert.

This feature can be applied to both the standard helical knurled parts and customer defined knurl profiles.

Some customers have developed their own internal company standards for miniature inserts.

One common deviation from our standard helical knurl is the use of a male cross cut (diamond) knurl.

MINI-TECH and HEADED MINI-TECH can be supplied with this knurl profile.

MINIATURE DIRECT SCREW FIXINGS – TMP SERIES

The TMP Screw is a range of direct screw fasteners for use in thermoplastics. The key design aspects include a profiled thread root to assist plastic flow, a 30° flank angle to reduce boss bursting forces and an 8° pitch angle which combine to give low installation torques with high stripping torques. For those applications not requiring the high levels of thread re-use and high clamping torque, (properties associated with threaded inserts) TMP screws offer an economical solution to plastics assembly and has distinct advantages over other direct screw fixings.

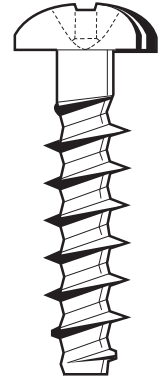

ADVANTAGES

- Reduced installation torque
- High stripping torque
- Greater safety margin between installation torque and stripping torque
- High parent material shear strength
- Minimizes material flow resistance
- Designed to reduce stress within the thermoplastics to an absolute minimum
- High resistance to vibration and relaxation
- Allows for smaller bosses

DESIGN GUIDE

When choosing a direct screw fixing one of the major criterion is to obtain the maximum margin between driving torque and stripping torque. Screw design, material characteristics, moulding practice, hole size and installation speed all have an influence.

The specialised equipment necessary to measure the effect of these factors is available at Bulten’s Technology Centres. This allows customers to obtain the best design possible.

Pre-production testing is therefore strongly recommended.

Please note the inclusion of a counterbore – this is important for the following reasons:

- Prevents damage to the top of the boss
- Helps alignment of the screw in the boss
- Assists in repeated assemblies of the screw
- Acts as a relief for any material extruded to the head of the screw and allows flush finishes.

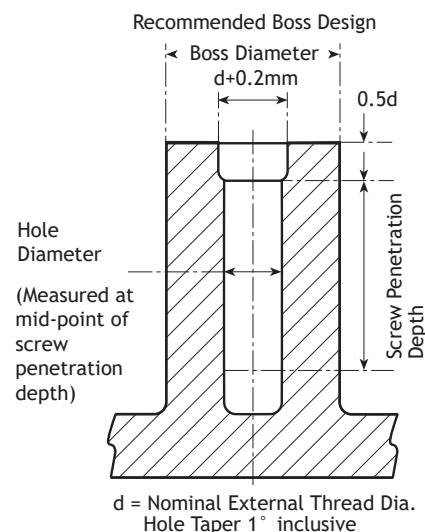

N.B. If moulded tool design or application into an existing boss renders the recommended boss design impractical, please contact Bulten for specific advice.

MINIATURE DIRECT SCREW FIXINGS – TMP SERIES

DESIGN FEATURES

8° OPTIMUM PITCH ANGLE

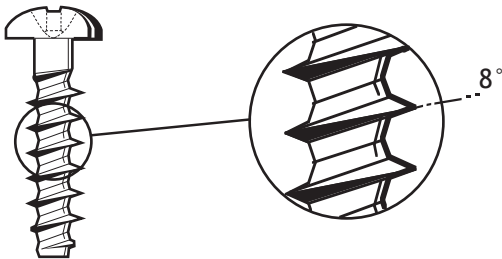

- Lowest installation torque/highest stripping torque
- Maximum resistance to vibration loosening and material relaxation in the component

PROFILED THREAD ROOT

Flat Root thread v TMP Profiled Root thread

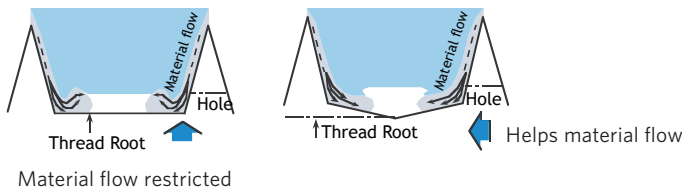

- Improved plastic flow reduces stress, providing long term reliability
- Greater surface area contact between screw thread and plastic, to give a high shear and stripping torque
- Lower installation torques

30° COMBINED FLANK ANGLE

60° Flank Angle V 30° Flank Angle

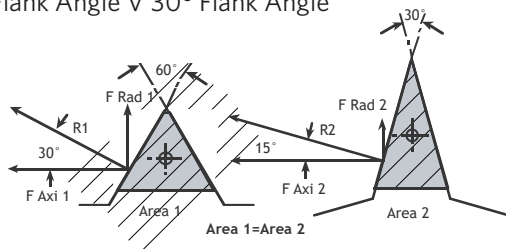

- Lower radial stresses, reducing boss bursting force. Greater thread penetration into the plastic material, permitting enhanced clamping torque. Lower installation torques
- Reduced centre of pressure, producing lower installation torque

Resolution of Resultant Forces for the Same Volume Displacement

$$F_{Rad 1} = 0.500R \quad F_{Rad 2} = 0.259R$$

$$F_{Axi 1} = 0.867R \quad F_{Axi 2} = 0.966R$$

DESIGN RECOMMENDATION

Material	Hole Diameter	Boss Diameter	Min. Screw Penetration Depth
ABS	0.8d	2d	2d
ABS/PC Blend	0.8d	2d	2d
ASA	0.78d	2d	2d
PA 4.6	0.73d	1.85d	1.8d
PA 4.6 - GF 30	0.78d	1.85d	1.8d
PA 6	0.75d	1.85d	1.7d
PA 6 - GF 30	0.8d	2d	1.9d
PA 6.6	0.75d	1.85d	1.7d
PA 6.6 - GF 30	0.82d	2d	1.8d
PBT	0.75d	1.85d	1.7d
PBT - GF 30	0.8d	1.8d	1.7d
PC	0.85d	2.5d	2.2d*
PC - GF 30	0.85d	2.2d	2.0d*

For other materials contact Bulten.

Material	Hole Diameter	Boss Diameter	Min. Screw Penetration Depth
LDPE	0.7d	2d	2d
HDPE	0.75d	1.8d	1.8d
PET	0.75d	1.85d	1.7d
PET - GF30	0.8d	1.8d	1.7d
PMMA	0.85d	2d	2d
POM	0.75d	1.95d	2d
PP	0.7d	2d	2d
PP-TF20	0.72d	2d	2d
PPO	0.85d	2.5d	2.2d*
PS	0.8d	2d	2d
PVC(Hard)	0.8d	2d	2d
SAN	0.77d	2d	1.9d
PPS	Comtact Bulten		

* Where materials are known to be sensitive to environmental stress cracking, ageing tests should be carried out as recommended by the material manufacturer.

MINIATURE DIRECT SCREW FIXINGS – TMP SERIES

DIMENSIONS

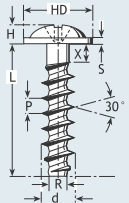
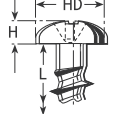
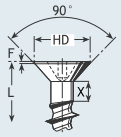
		Nominal Diameter		K12	K14	K15	K16	K18	K20	K22	K25
PRODUCT CODE TMP 14	External Thread	d		1.2	1.4	1.5	1.6	1.8	2	2.2	2.5
	Thread Root	R		0.74	0.84	0.89	0.92	1.04	1.15	1.25	1.40
	Thread Pitch	P		0.53	0.62	0.67	0.67	0.80	0.89	0.98	1.12
	Plain Section X Max	Screw Lengths > 3d			1.2	1.4	1.5	1.6	1.8	2.0	2.2
Screw Lengths ≤ 3d				0.6	0.7	0.8	0.8	0.9	1.0	1.1	1.3
HEAD STYLE 11 Pan Flange 	Head Diameter	HD		-	-	-	-	-	4.0	4.4	5.0
	Head Height	H		-	-	-	-	-	1.4	1.6	1.8
	A PHILLIPS	Recess No		-	-	-	-	-	PH1	PH1	PH1
	B POZI	Recess No		-	-	-	-	-	PZ1	PZ1	PZ1
	Head Diameter	HD		-	-	-	-	-	4.0	4.5	5.0
	Head Height	H		-	-	-	-	-	1.3	1.4	1.5
HEAD STYLE 12 Pan. 	Head Diameter	HD		2.2	2.4	2.6	2.6	3.2	3.5	3.9	4.4
	Head Height	H		0.9	1.0	1.1	1.1	1.2	1.4	1.5	1.7
	A PHILLIPS	Recess No		PH0	PH0	PH0	PH0	PH0	PH1	PH1	PH1
	B POZI	Recess No		PZ0	PZ0	PZ0	PZ0	PZ0	PZ1	PZ1	PZ1
	Head Diameter	HD		2.4	2.8	-	3.2	3.6	3.6	4.0	4.2
	Head Height	H		0.9	1.0	-	1.1	1.3	1.5	1.4	1.6
HEAD STYLE 13 Countersunk 90° 	Head Diameter	HD		-	-	-	-	3.0	3.8	3.8	4.7
	Cylinder Head Height	F		-	-	-	-	0.25	0.25	0.25	0.45
	A PHILLIPS	Recess No		-	-	-	-	PH0	PH1	PH1	PH1
	B POZI	Recess No		-	-	-	-	PZ0	PZ1	PZ1	PZ1
	Head Diameter	HD		-	-	-	-	3.4	3.8	3.8	4.7
	Head Height	F		-	-	-	-	0.25	0.25	0.25	0.45
C 6-LOBE	Recess No		-	-	-	-	T6	T6	T6	T6	T8

MINIATURE DIRECT SCREW FIXINGS – TMP SERIES

SIZE RANGE

TMP Screws	K12	K15	K16	K18	K20	K22	K25
Length L (mm) Nominal Ø(mm)	1.2	1.5	1.6	1.8	2.0	2.2	2.5
3 ± 0.38							
3.5 ± 0.38							
4 ± 0.38							
4.5 ± 0.38							
5 ± 0.38							
6 ± 0.38							
7 ± 0.45							
8 ± 0.45							
9 ± 0.45							
10 ± 0.45							
12 ± 0.55							
14 ± 0.55							
15 ± 0.55							
16 ± 0.55							
18 ± 0.55							
20 ± 0.65							
22 ± 0.65							
25 ± 0.65							
30 ± 0.65							

HEAD STYLE 13 L min = L min + 2mm

HOW TO SPECIFY

Screw Type	TMP1412-KB18x6-Z
Head Style	TMP14 12 -KB18x6-Z
Recess Code	TMP1412-K B 18x6-Z
Thread Diameter	TMP1412-K B18 x6-Z
Length Of Screw	TMP1412-KB18x 6 -Z
Finish No	TMP1412-KB18x6- Z

MINIATURE DIRECT SCREW FIXINGS – TMP SERIES

ASSEMBLY DATA

To determine the optimum performance of direct screw fixings there are a number of influential factors which have to be considered if problems on the production line or in service are to be avoided. In order to establish the optimum clamping torque it is first necessary to establish the following:

1. Amount of torque required to form the first thread.
2. The amount of torque required for the screwhead to come into contact with the mating component.
3. The amount of torque required for the joint to fail.

These figures should be obtained by the use of specialised equipment which simulates production line conditions since testing by hand omits the important effect of friction due to installation speed. Bulten's Technology Centres are fully equipped to conduct these tests for you.

The repeat torque accuracy of the installation tool can vary and should always be considered when specifying the recommended clamping torque.

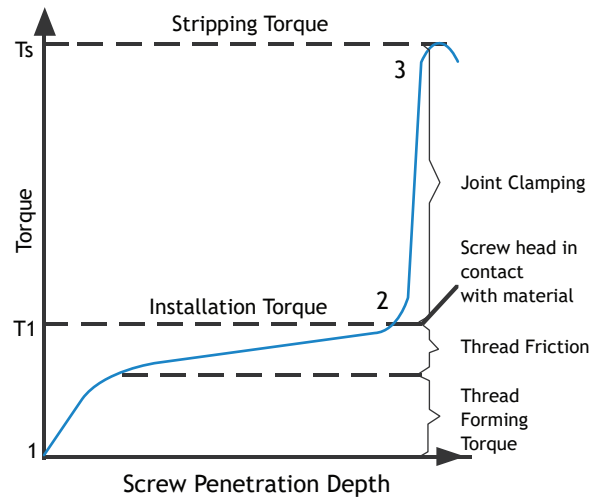
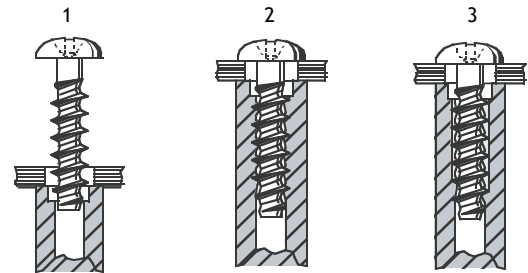

RECOMMENDED INSTALLATION TOOL SPEEDS

The speed at which screws are installed should be carefully considered – speeds which are too high can destroy the material into which the screws are being driven.

Although a speed of 600rpm is recommended for most materials, pre-production testing and consultation with Bulten should be undertaken for optimum results.

MINI-SMF

MINI-SMF is range of miniature threaded fasteners developed specifically for use in thin sheet Mobile Phone applications. The various types, Laser Weld, Riveting and Self-Clinch, allow designers to select a part to exactly suit their application and assembly requirements.



ADVANTAGES

- Re-usable high strength threads
- Eliminates thin sheet tapping problems
- Miniature, compact and light weight
- A range of designs available
- Manufactured specifically to meet exact customer requirements
- Designs to suit a variety of host materials and assembly methods
- Manufactured from Stainless steel, Steel, Brass & Aluminium
- Thread size range M1.2, M1.4, M1.6, M2

DESIGN GUIDE

3-1 LASER WELD

Laser welding is the most common method of attaching miniature threaded fasteners to thin stainless steel sheet. The welding process gives very good torque and pull out resistance and allows the fasteners to be positioned very close to the edge of the sheet.

Fasteners can be supplied both through and blind threaded, with and without a sheet location diameter.

Typical examples are shown below.

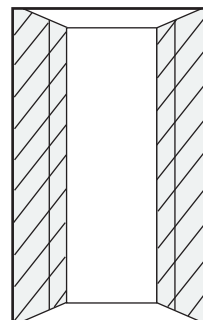

Through Threaded
Without Location

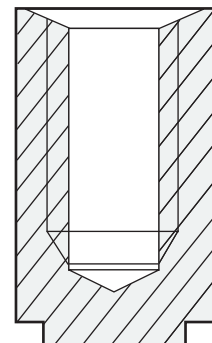

Blind Threaded
With Location
Diameter

MINI-SMF

3-2 RIVETING

Riveting is a proven method of mechanically attaching fasteners to thin sheet metal. The counterbored shank is placed through a pre-formed hole in the host sheet metal, a profiled punch is then used to rivet the shank onto the face of the sheet. The riveted shank provides a resistance to both pull-out and torque.

When the host material is soft such as aluminium, a serrated shank is recommended. During the riveting process the serrations bite into the surface of the sheet and the wall of the preformed hole, providing a high resistance to turning.

When the host material is hard such as stainless steel, a stainless steel serrated rivet bush can be selected. Where a brass or aluminium fastener material is required, we recommend the use of a plain shank and profiled hole. This method provides a good resistance to turning where a serrated shank will not penetrate the harder host material.

Typical examples are shown below.

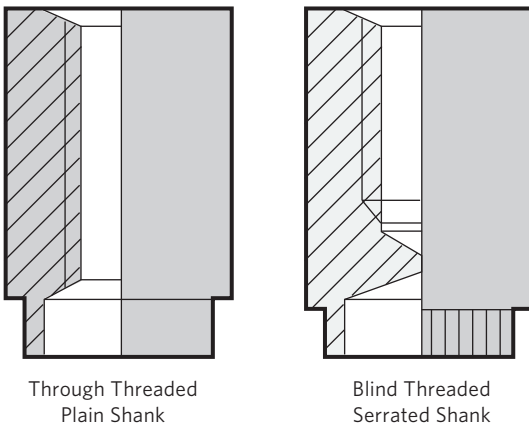

3-3 SELF-CLINCH

Self-Clinching works on the principle that the fastener is sufficiently harder than the host sheet material, allowing the fasteners clinch profile to displace the host sheet material during insertion.

The clinch profile is fully contained within the thickness of the sheet and provides anti-rotational and push out resistance. Hence it is more suited to slightly thicker and softer materials such as aluminium alloys.

Typical examples are shown below.

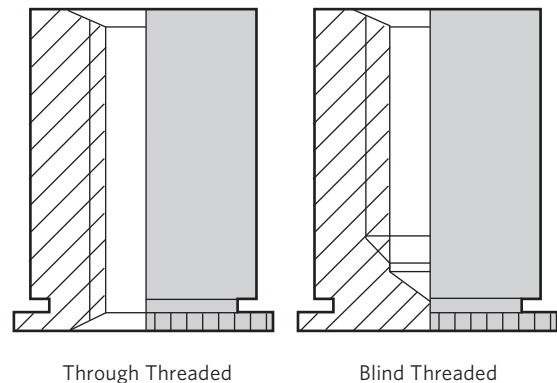

HOW TO SPECIFY

Due to the variety of product types, fastener and host materials, thread sizes and body sizes, this product is an Applications Engineered fastening solution. Please contact your local Bulten Technology Centre or Sales Office where a suitable product will be recommended to meet your exact application requirement.

NYLON PATCH PROCESSING

Bulten can offer a wide range of thread locking and sealing solutions, eliminating the need for secondary locking devices. Nylon Patch when applied, is permanently fused onto the thread of the screw or threaded component. The patch increases the prevailing torque and provides excellent vibration resistance, allowing the screw to be locked in any position when assembled.



ADVANTAGES

- Visible thread locking device
- Permanently attached
- Re-useable
- Anti-vibrational
- Variable patch position and length
- Can be specified to seal
- Chemical resistant
- Free running thread start

DESIGN GUIDE

THREADED HOLE PREPARATION

All female mating threads should have an adequate thread lead to prevent damage to the Nylon Patch during assembly.

THREAD PREPARATION

To obtain optimum patch performance, both the male and female threads should be in accordance with the relevant International thread class.

FINISHES

Nylon Patch can be applied to most popular plated finishes, including polymer and organic coatings. The nylon patch is fused onto a defined area of the male thread.

During installation, the nylon patch is compressed, taking up the tolerance between the male and female threads. This creates a strong metal to metal radial loading on the flanks of the thread forms, which provides the locking action.

NYLON PATCH PRINCIPLE

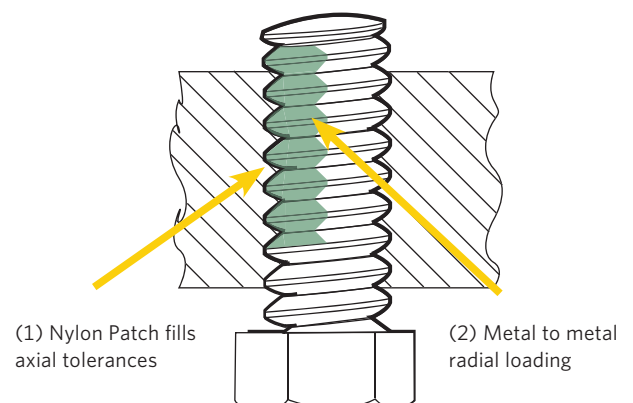

NYLON PATCH PROCESSING

PRODUCT RANGE

NYLON PATCH 180

The Nylon Patch 180 is permanently fused to an area, covering approximately 180° of the circumference of screw thread. The process provides excellent vibration resistance for applications requiring controlled threadlocking and re-usability.

NYLON PATCH 360

The Nylon Patch 360 is permanently fused to the full circumference of the screw thread and is suitable for applications requiring a fully re-usable high pressure seal against liquid or gas.

TECHNICAL DATA

Product	Type	Max Patch Length	Standard Patch Length	Standard Patch Lead	Storage Life @ Ambient Conditions	Operating Temp (0°C)	Standard Capacity 360 Patch	Re-Usability	Size Range
Nylon Patch	Nylon	40mm	4-6 Pitch	1-2 Pitch Lead	Indefinite	-56 +150	>15 BAR (M10 Thread)	>5	M1-M30

We can apply Nylon Patch to ferrous or non ferrous materials (Steel, Aluminium, Stainless Steel or Brass).

STANDARD TORQUE CHARACTERISTICS

Thread Sizes	First Installation		First Removal		Fifth Removal	
	Prevailing Torque Max.		Min.		Min.	
ISO Metric	lbf/in	Nm	lbf/in	Nm	lbf/in	Nm
1.6	0.9	0.10	0.1	0.01	0.035	0.004
2	1.8	0.20	0.2	0.02	0.10	0.01
2.5	3.5	0.40	0.4	0.05	0.3	0.03
3	5.3	0.60	1.2	0.14	0.50	0.06

Torque performance can be varied to suit specific application requirements. The figures shown above are typical and are intended as a guide to performance.

INDUSTRY APPROVALS

Nylon Patch can be supplied to meet a wide range of industry standards including: DIN 267 part 28, BS7715:1994, IFI # 524, General Motors, Ford WA970, Rover RES.22.FP.02, Jaguar JFS.02.01.04 Plus many other industry approvals.

Where the Nylon Patch has to meet a particular standard, this must be specified when requesting a quotation and when placing an order.